

MISSION DATA CARD

OPORD		Callsign		Mission		Date/Time		
3339/2024		Edelweiss 1		Training		210000OCT24		
Task	BJT Checkride					Freq		
AO	NTTR					135.0		
Departure				Recovery				
FYTTR LOW				STRYK				
#	Callsign		Pilot		IFF	TCN	LSR	NET
-1	Edelweiss 1-1		Beathovenz		1711	1Y	1711	
-2	Edelweiss 1-2		Nerkub		1712	64Y	1712	

LOADOUT

A/A						GUN	100% HEI-T
A/G						CHF	120
POD						FLR	0
TKS	FT300					FUEL	100%

TOLD

	Takeoff	Target	Joker	Bingo	Land
FUEL	9166			2000	

AIRBASES

	Name	TCN	ATIS	GND	TWR	RWY	Elev	ILS
Dep	Nellis AFB	12X	270.1	275.8	327.0	21L	1850	109.1
Arr	Nellis AFB	12X	270.1	275.8	327.0	21L	1850	109.1
Div	Creech AFB	87X	290.45	275.8	360.6			

FLIGHTPLAN

#	Name	Navaid/Coords/DME	ALT	TOT
1	FLEX	N36 18.620 W115 02.360	4000	
2	DME Arc 15	N36 21.610 W115 17.970	5000	
3	R-269	N36 17.760 W115 19.670	8000	
4	FYTTR	N36 21.440 W115 41.470	14000	
5	Creech	N36 35.030 W115 40.480	15000	
6	STRYK	LSV 282/26 (N36 25.620 W115 30.700)	9500	
7	GASS PEAK	N36 24.140 W115 10.660	8500	
8	SIMNS	N36 17.340 W115 10.750	5500	
9	CRAIG	N36 15.250 W115 08.270	5000	
10	APEX	LSV 027/09 (N36 21.580 W114 54.340)	5000	
11	PHINN	N36 18.427 W114 57.408	4000	

COMMS

Radio	Usage
1	11 [ATIS], 3 [Nellis Gr], 4 [Nellis Tr], 16 [Blackjack]
2	135.00 [Inhouse]
3	16 [Blackjack], 11 [ATIS], 4 [Nellis Tr], 3 [Nellis Gr]

NOTES

Departure: FYTTR LOW

Recovery: STRYK

FLEX

GASSPEAK

APEX

Overhead - 3.500ft MSL, 350 KIAS

Downwind - 3.500ft MSL, 220 - 250 KIAS, LDG, Lights

Immelmann - 400 KIAS, A/B

Split-S - 5° dann inverted

Aileron Roll - 3°, Roll

Barrell Roll - 45° = 90° AOB, 90° = 180° AOB

Looping - 400KIAS A/B

Chandell - Gleichmäßig Höhe & Kurs

Unload - 0G bis Speed/Height

Lift Limit Pull - Bis Speed/Kurs

RADIO CHANNELS

#	Freq	Name
1		Flight/Squadron specific
2	289.4	Nellis Clearance Delivery
3	275.8	Nellis Ground
4	327.0	Nellis Tower
5	385.4	Nellis Approach/Departure West
6	273.55	Nellis Approach/Departure East
7	317.525	Nellis Control -- Sally
8	254.4	Nellis Control-- Lee
9	305.6	SOF Bullseye
10	343.725	EMERGENCY SINGLE FRQ
11	270.1	Nellis ATIS
12	360.625	Creech AFB Tower
13	250.1	HAVE QUICK 13
14	251.1	HAVE QUICK 14
15	252.1	HAVE QUICK 15
16	377.8	Blackjack
17	265.0	KC-135 AR-641A
18	360.8	KC-135MPRS AR-635
19	319.8	KC-135MPRS AR-625
20	300.05	KC-135 AR-231V

RAMROD

0	1	2	3	4	5	6	7	8	9
M	I	S	F	O	R	T	U	N	E

KTC 1400 C

	0	1	2	3	4	5	6	7	8	9
A	MOVJ	PGT	QAS	KY	HC	IUB	RX	FL	WD	NE
B	XDYF	KTQ	MJS	OE	PI	NAB	VU	GH	WR	LC
C	WCID	PHR	FOV	YJ	NG	MEB	AL	QT	XK	SU
D	GQAY	UKW	MTJ	BF	PC	HID	RX	SL	VO	EN
E	LJPQ	EXF	URK	OD	YV	AHN	BI	TM	WG	SC
F	MHBP	LJG	XIU	TV	DS	KRN	FQ	AY	EW	CO
G	AEWJ	UPD	XBK	CN	FY	TLS	RO	IG	HM	VQ
H	HLBX	FYN	MDS	VJ	QA	EUO	WK	RP	GC	IT
I	PONJ	LUW	CBQ	RF	GK	MHI	DX	YE	VT	AS
J	YGTC	PKM	JIN	VL	HA	QWO	EU	FX	DB	RS
K	GEVR	KNX	UOL	DJ	HA	MYB	SW	IQ	CT	FP
L	TGWU	YPA	KBL	XD	FO	EMR	QN	SH	IJ	VC
M	YQWF	CUG	HTX	LM	AO	NES	JD	VK	IB	RP
N	LEDS	GIP	WRO	TV	QB	NJU	KC	HX	FY	MA
O	OCWF	TGH	DBA	YM	RP	VJS	UE	IL	KX	QN
P	OGLE	YAH	TBS	QR	DX	JPM	IC	VW	KN	FU
Q	UIRM	BLO	VKY	CS	AJ	FTD	XQ	GP	NE	HW
R	AGRM	KLB	XCN	WY	DS	FJE	TO	VQ	UP	HI
S	FSIX	ORY	PMH	NB	UV	GCD	QL	JW	EK	TA
T	BQYM	PRT	NWF	EA	GH	OJS	UX	IV	DC	LK
U	VEKQ	UCH	NTW	RG	IP	FXA	OB	MD	JY	LS
V	TWPH	SNV	JGR	LE	OA	BIY	XQ	FD	UC	MK
W	JWQG	YOA	NIC	UB	RL	TEX	FD	PS	MV	HK
X	JLTQ	POK	SNH	WD	FV	MYX	AU	CB	GE	RI
Y	DOEW	VTJ	NRL	QC	XY	AFS	KI	GU	PB	MH

NAVAIDS

Id	Name	Channel	Position	Elevation
BCE	Bryce Canyon	75	N3741.35 W11218.23	9040
BIH	Bishop	33	N3722.62 W11821.99	4114
BLD	Boulder	114	N3559.75 W11451.82	3650
BTY	Beatty	94	N3648.54 W11644.86	2925
CDC	Cedar City	120	N3747.24 W11304.90	5463
DAG	Daggett	79	N3457.75 W11634.69	1760
EED	Needles	99	N3445.96 W11428.43	650
GFS	Goffs	91	N3507.87 W11510.59	4019
GRL	Groom Lake	18	N3713.91 W11548.16	4475
HEC	Hector	74	N3447.83 W11627.78	1854
ILC	Wilson Creek	110	N3815.02 W11423.65	9318
INS	Creech AFB	87	N3635.20 W11540.12	3101
LAS	McCarran Intl	116	N3604.78 W11509.59	2142
LSV	Nellis	12	N3614.68 W11501.50	1864
MLF	Milford	58	N3821.62 W11300.79	4977
MMM	Mormon Mesa	90	N3646.16 W11416.65	2120
MVA	Mina	98	N3833.92 W11801.97	7860
OAL	Coale Dale	124	N3800.20 W11746.23	4800
PGS	Peach Springs	57	N3537.48 W11332.67	4754
TPH	Tonopah Muni	119	N3801.84 W11702.01	5330
TQQ	Silverbow	77	N3748.00 W11647.00	5500
UTI	St George	23	N3705.29 W11335.53	2871



RWY 3L-21R
 PCN 46 R/C/W/T
 RWY 3R-21L
 PCN 51 R/C/W/T
 2017

PAR	RWY	CAT	MINIMA		ARP	ELEV	Scale 1:35'500	
	21L	A B D E	2057 - 0.8 200	(200-0.8/1.6) GS 3°	36° 14.060° N 115° 01.058° W	1857 [ft] 566 [m]	0 300 600 900 1200 1500 [m]	
	3R	A B D E	2057 - 0.8 200	(200-0.8/1.6) GS 3°			0 1000 2000 3000 4000 5000 [ft]	
	21R	A C D E	2257 - 1.2 350	(350-1.2/1.6)				
	3L	A C D E	2257 - 1.2 350	(350-1.2/1.6)				

RWY	TORA	TODA	ASDA	LDA	PSN	THR	ALS
21L	10051 [ft] 3063 [m]	11051 [ft] 3368 [m]	11051 [ft] 3368 [m]	10051 [ft] 3063 [m]	36°14.043' N	115°01.018' W	⊕
3R	10120 [ft] 3084 [m]	11120 [ft] 3398 [m]	11120 [ft] 3398 [m]	10120 [ft] 3084 [m]	36°13.029' N	115°02.038' W	

ATIS	NELLIS GROUND	NELLIS TOWER	NELLIS CONTROL	TACAN	ILS RWY 21L	NELLIS EAST	NELLIS WEST
270.100 MHz	275.800 121.800	327.000 132.55	317.525	LSV 12X	109.10 Mhz	384.400	385.000

ATIS
270.100
NELLIS GROUND
275.800
NELLIS TOWER
327.000
NELLIS CONTROL
317.525
NELLIS DEP/APP EAST
384.400
BLACKJACK
377.800

CAUTION: If unable to comply
with restrictions advise ATC
prior to departure.



VMC ONLY

PILOT RESPONSIBLE FOR TERRAIN AVOIDANCE

① 4 NM from RWY 3L/R

BEATTY
Chan 94 BTY

RANGE 64/65
RANGE 63

TUCKY

R-2508

LSV R-269

FYTTR
N3621.44
W11541.47

BTY R-105

DME 15 ARC
5000

7233
FLEX
LSV 337/5

2086 M

①

3000

NELLIS
Chan 12 LSV

R-255
6000
5000

300°

4131

v.186502 NITTR NAV CHART



DEPARTURE ROUTE DESCRIPTION

TAKEOFF RWY 3L/R:

- Remain below 3,000' MSL until north of Race Track and turned westbound.
- Turn left within 4NM of Nellis direct FLEX. Fly north of FLEX and turn left heading 270°.
- Intercept LSV 15 DME ARC at or below 5,000' MSL.
- ARC south, intercept LSV R-269 outbound. Maintain VFR.

TAKEOFF RWY 21L/21R:

- Follow Noise Abatement Procedures.
- Fly runway heading until past Golf Course, turn right heading 300°.
- Cross LSV R-255 between 5,000' and 6,000' , intercept and proceed outbound on the LSV R-269.Recommend climb to 8,500' MSL or appropriate VFR altitude for overflight of North Las Vegas Training Area. Fly routing for appr. mission/transition.

TRANSITIONS:

- R-4806:** Turn right at the LSV 269/20 direct to assigned ranges.
- BEATTY:** Turn right at FYTTR direct BTY via the BTY R-105
- R-2508:** Turn right at the FYTTR, intercept the BTY 105/30, direct TUCKY, then direct R-2508

FYTTR DEPARTURE AND TRANSITIONS (FYTTR LOW)

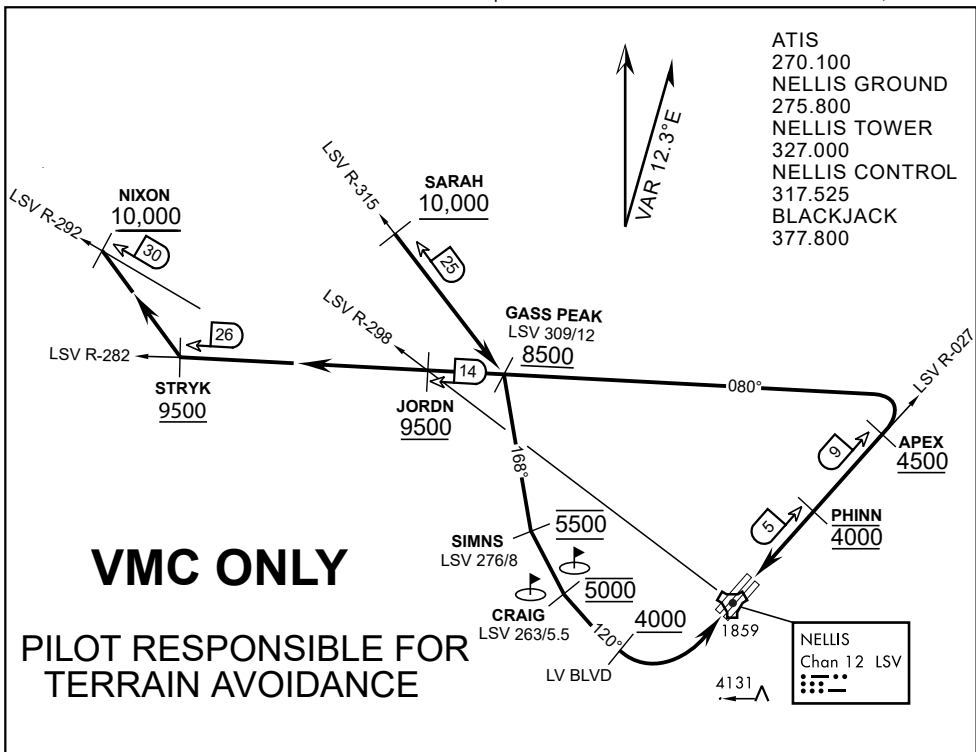

APPROACH ROUTE DESCRIPTION

APPROACH RWY 3L/R

Cross STRYK at or above 9,500' MSL, proceed direct GASS PEAK. Cross JORDN at or above 9,500' MSL, cross GASS PEAK at or above 8,500' MSL. Proceed direct SIMNS and cross at 5,500' MSL. Cross Las Vegas Blvd at or above 4,000' MSL then to 3,500' MSL for Initial. Remain within 4 DME if LSV on turn to final.

VFR STRAIGHT-IN RWY 3L/R

Depart CRAIG & descend to be at 3,000' MSL by Las Vegas Blvd. Do not descend below 3,000' MSL until within 5 DME of LSV or 4 NM of the runway on turn to final.

APPROACH RWY 21L/R

Cross STRYK at or above 9,500' MSL, proceed direct GASS PEAK. Cross JORDN at or above 9,500' MSL, cross GASS PEAK at or above 8,500' MSL. Cross APEX at or above 4,500' MSL then direct 5NM initial. Descend to cross PHINN at 4,000' MSL, Inside 5 NM descend to 3,500' MSL.

VFR STRAIGHT-IN RWY 21L/R

Cross APEX at 4,000' MSL. Descend to be at 3,000' MSL at PHINN. Descend to 3,000' MSL at LSV 027/5.

RANGE 63B EXIT

SOUTH: Via NIXON at or above 10,000' MSL, then direct STRYK.

EAST: Via SARAH at or above 10,000' MSL, then direct GASS PEAK.



INDIAN SPRINGS, NEVADA

TACAN INS Chan 87	APCH CRS 065°	Rwy ldg TDZE 3133	9002 3113
		Arpt Elev 3113	

INDIAN SPRINGS AF AUX (KINS)

▼ * MISSED APPROACH: Straight ahead to INS TACAN, intercept INS R-outbound, cross 17 DME at or above 9500, then direkt KSV TACAN 114

NELLIS CON

CREECH AFB TOWER
118.30 60.60

GND CON

NOT FOR CIVIL USE

FOR USE UNDER BASIC VFR
WEATHER MINIMUMS ONLY

PILOT IS RESPONSIBLE FOR TERRAIN/OBSTACLE AVOIDANCE AND APPROPRIATE VFR CLOUD CLEARANCE FOR ALL

CAUTION: Descent gradients are greater than allowed under standard TERPS criteria and inbound course does not meet straight-in criteria

CAUTION: Final approach course crosses Runway centerline at MIDFIELD. Maneuvering left of course required prior to landing. Do not Maneuver farther north than the INS R- 258

Modified by viaBog 66 for use with DCS
NOT FOR REAL LIFE NAVIGATION

Modified by viaBog 66 for use with DCS
NOT FOR REAL LIFE NAVIGATION

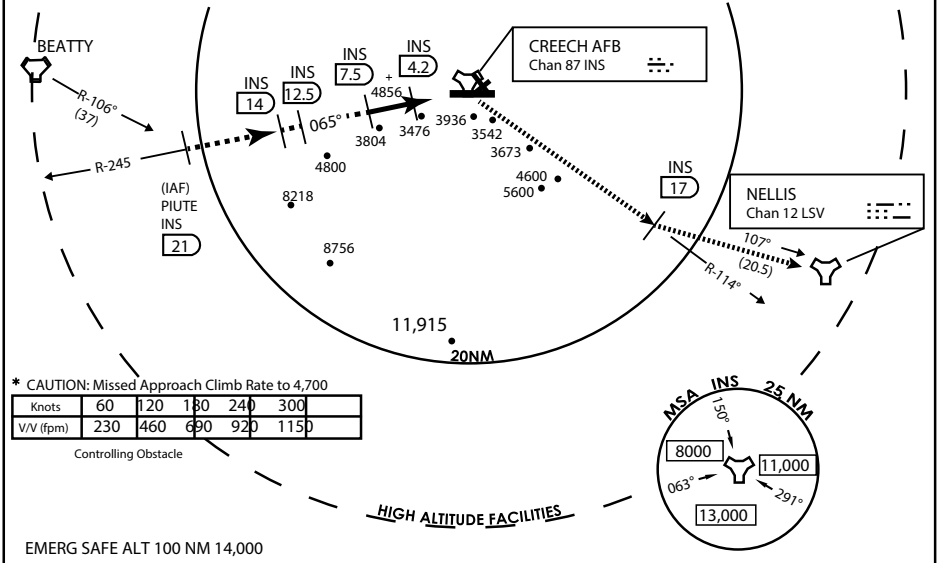

* CAUTION: Missed Approach Climb Rate to 4,700

Knots	60	120	180	240	300
V/V (fpm)	230	460	690	920	1150

Controlling Obstacle

HIGH ALTITUDE FACILITIES

EMERG SAFE ALT 100 NM 14,000

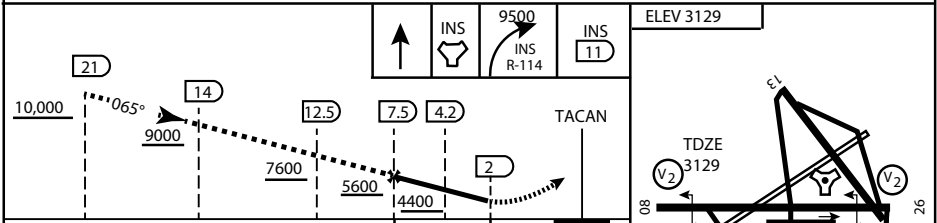

CATEGORY	A	B	C	D	E
S-8	3760-1 ½	627 (700-1 ½)	3760-1¾ 627 (700-1¾)	3760-2 627 (700-2)	3760-2¼ 627 (700-2¼)
CIRCLING	NOT AUTHORIZED				

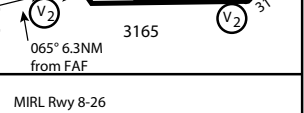

CITY OF INDIAN, NEVADA

INDIAN SPRINGS AF AUX (KINS)

(FOR DAY VFR USE ONLY)



AIRPORT DIAGRAM

476 VFG

CREECH AFB (KINS)
INDIAN SPRINGS, NEVADA

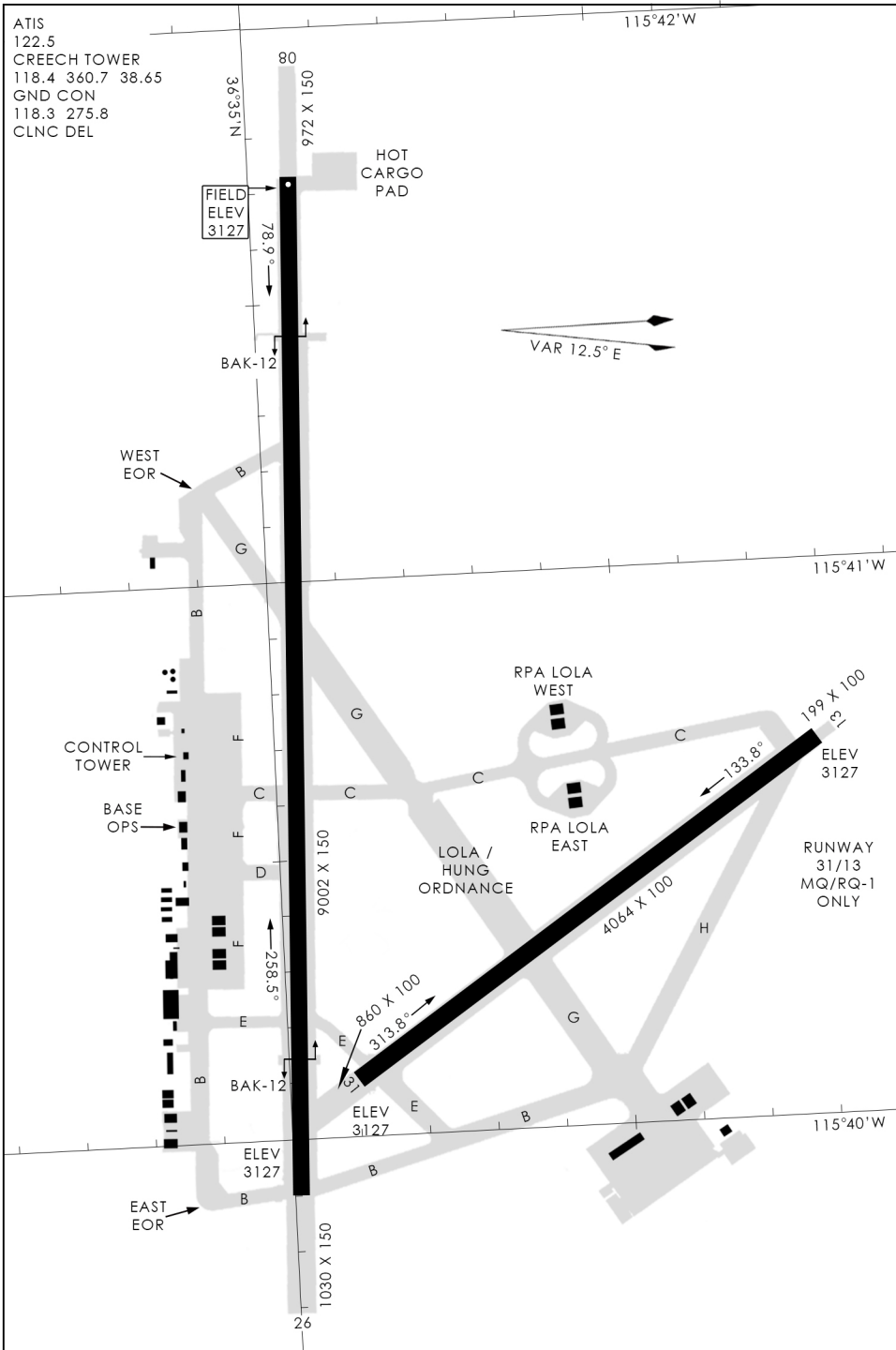

476 VFG JAN 2019

476 VFG JAN 2019

AIRPORT DIAGRAM

INDIAN SPRINGS, NEVADA
CREECH AFB (KINS)