

MISSION DATA CARD

OPORD		Callsign		Mission		Date/Time		
3232/2024		Edelweiss 3		Training		220823SEP24		
Task	TRAINING					Freq		
AO	RANGE 64C					264.35		
Departure				Recovery				
FYTTR LOW				STRYK				
#	Callsign		Pilot		IFF	TCN	LSR	NET
-1	Edelweiss 3-1		Coach		1731	1Y	1731	

LOADOUT

A/A	2xA9X				GUN	100% HEI-T	
A/G	4xM82				CHF	120	
POD					FLR	0	
TKS	FPU-8A				FUEL	100%	

TOLD

	Takeoff	Target	Joker	Bingo	Land
FUEL	13047				

AIRBASES

	Name	TCN	ATIS	GND	TWR	RWY	Elev	ILS
Dep	Nellis AFB	12X	270.1	275.8	327.0	21L	1850	109.1
Arr	Nellis AFB	12X	270.1	275.8	327.0	21L	1850	109.1
Div	Creech AFB	87X	290.45	275.8	360.6			

FLIGHTPLAN

#	Name	Navaid/Coords/DME	ALT	TOT
1	FLEX	N36 18 37.200 W115 02 21.600	3000	
2	FYTTR	N36 21 26.400 W115 41 28.200	14000	
3	IP WHISKEY	N36 37 52.687 W115 49 21.173	18000	
4	RANGE 64C	N36 37 52.687 W115 40 24.454	18000	

COMMS

Radio	Usage
1	3, 4, 16, 4, 3
2	.264.35, MIDS A23, 288.8

NOTES

WHISKEY PATTERN, RANGE64C CIRCLE WEST

SUPPORT**Tanker**

Callsign	TCN	Freq	ALT	TAS
ARCO 1	113Y	319.8	FL250	450
Pos	AR-625: MVA 168/77 (N3717 W11802)			

RADIO CHANNELS

#	Freq	Name
1		Flight/Squadron specific
2	289.4	Nellis Clearance Delivery
3	275.8	Nellis Ground
4	327.0	Nellis Tower
5	385.4	Nellis Approach/Departure West
6	273.55	Nellis Approach/Departure East
7	317.525	Nellis Control -- Sally
8	254.4	Nellis Control-- Lee
9	305.6	SOF Bullseye
10	343.725	EMERGENCY SINGLE FRQ
11	270.1	Nellis ATIS
12	360.625	Creech AFB Tower
13	250.1	HAVE QUICK 13
14	251.1	HAVE QUICK 14
15	252.1	HAVE QUICK 15
16	377.8	Blackjack
17	265.0	KC-135 AR-641A
18	360.8	KC-135MPRS AR-635
19	319.8	KC-135MPRS AR-625
20	300.05	KC-135 AR-231V

RAMROD

0	1	2	3	4	5	6	7	8	9
P	L	A	Y	G	R	O	U	N	D

KTC 1400 C

	0	1	2	3	4	5	6	7	8	9
A	FOMG	LXB	HDI	KC	QY	JWS	ER	TA	VP	NU
B	GBCQ	YIO	NSH	KU	JD	WLP	TA	MX	EV	FR
C	WBUA	HRF	YTL	PM	IO	ESX	QJ	VG	NK	DC
D	RWLP	CAG	BJO	FD	QH	KES	VN	TU	IY	MX
E	TJPR	MKQ	VSH	WU	XE	NYC	DA	OI	FG	BL
F	LYKS	JCV	EGW	TN	UF	HAQ	MB	DX	PO	RI
G	CEVS	XRH	UOM	NF	PW	DYK	BI	GT	LJ	AQ
H	YFEH	SRP	VUK	QN	LX	DGM	OB	AC	JT	WI
I	DCBJ	IHX	WQR	SG	YT	VAU	MO	NP	LF	EK
J	HEAX	NBY	JTW	RP	LF	SQK	GI	OU	MC	VD
K	EYRP	KGS	FJT	VI	AQ	LOB	MW	DH	UC	XN
L	HQOU	XIL	FTJ	PN	BY	VRE	MS	AC	GK	WD
M	FXDT	LWO	PMS	VC	AR	QHN	YJ	EG	KI	BU
N	MLIY	OKW	VES	NQ	UT	XCJ	DP	FA	GB	RH
O	YBPJ	VWS	KIA	DX	LE	GRT	HM	QN	CU	FO
P	ESTR	UQA	PNH	FI	KW	MJG	DL	CX	YB	VO
Q	BRLA	SXG	NYO	TC	DE	FMK	QU	PI	JV	HW
R	NGHS	KCL	YBM	IQ	VX	FER	TA	OJ	UD	PW
S	EOWY	CMD	APK	NB	XQ	IJR	SG	VT	LH	FU
T	MTJR	VNX	FWK	GH	AU	QDY	PO	LI	SB	CE
U	NBYE	ICX	GOF	UQ	MR	VDK	AL	PW	ST	HJ
V	JHMF	AGU	DOB	NE	LQ	TRX	VI	CW	PK	SY
W	UKAX	FIN	VDQ	TR	LW	JYO	HS	EG	BP	MC
X	SFRP	NKO	UHE	LJ	VM	QDG	WT	CA	XB	IY
Y	JQFD	HUL	GRS	KX	PV	CWO	IB	YA	MT	EN

NAVAIDS

Id	Name	Channel	Position	Elevation
BCE	Bryce Canyon	75	N3741.35 W11218.23	9040
BIH	Bishop	33	N3722.62 W11821.99	4114
BLD	Boulder	114	N3559.75 W11451.82	3650
BTY	Beatty	94	N3648.54 W11644.86	2925
CDC	Cedar City	120	N3747.24 W11304.90	5463
DAG	Daggett	79	N3457.75 W11634.69	1760
EED	Needles	99	N3445.96 W11428.43	650
GFS	Goffs	91	N3507.87 W11510.59	4019
GRL	Groom Lake	18	N3713.91 W11548.16	4475
HEC	Hector	74	N3447.83 W11627.78	1854
ILC	Wilson Creek	110	N3815.02 W11423.65	9318
INS	Creech AFB	87	N3635.20 W11540.12	3101
LAS	McCarran Intl	116	N3604.78 W11509.59	2142
LSV	Nellis	12	N3614.68 W11501.50	1864
MLF	Milford	58	N3821.62 W11300.79	4977
MMM	Mormon Mesa	90	N3646.16 W11416.65	2120
MVA	Mina	98	N3833.92 W11801.97	7860
OAL	Coale Dale	124	N3800.20 W11746.23	4800
PGS	Peach Springs	57	N3537.48 W11332.67	4754
TPH	Tonopah Muni	119	N3801.84 W11702.01	5330
TQQ	Silverbow	77	N3748.00 W11647.00	5500
UTI	St George	23	N3705.29 W11335.53	2871

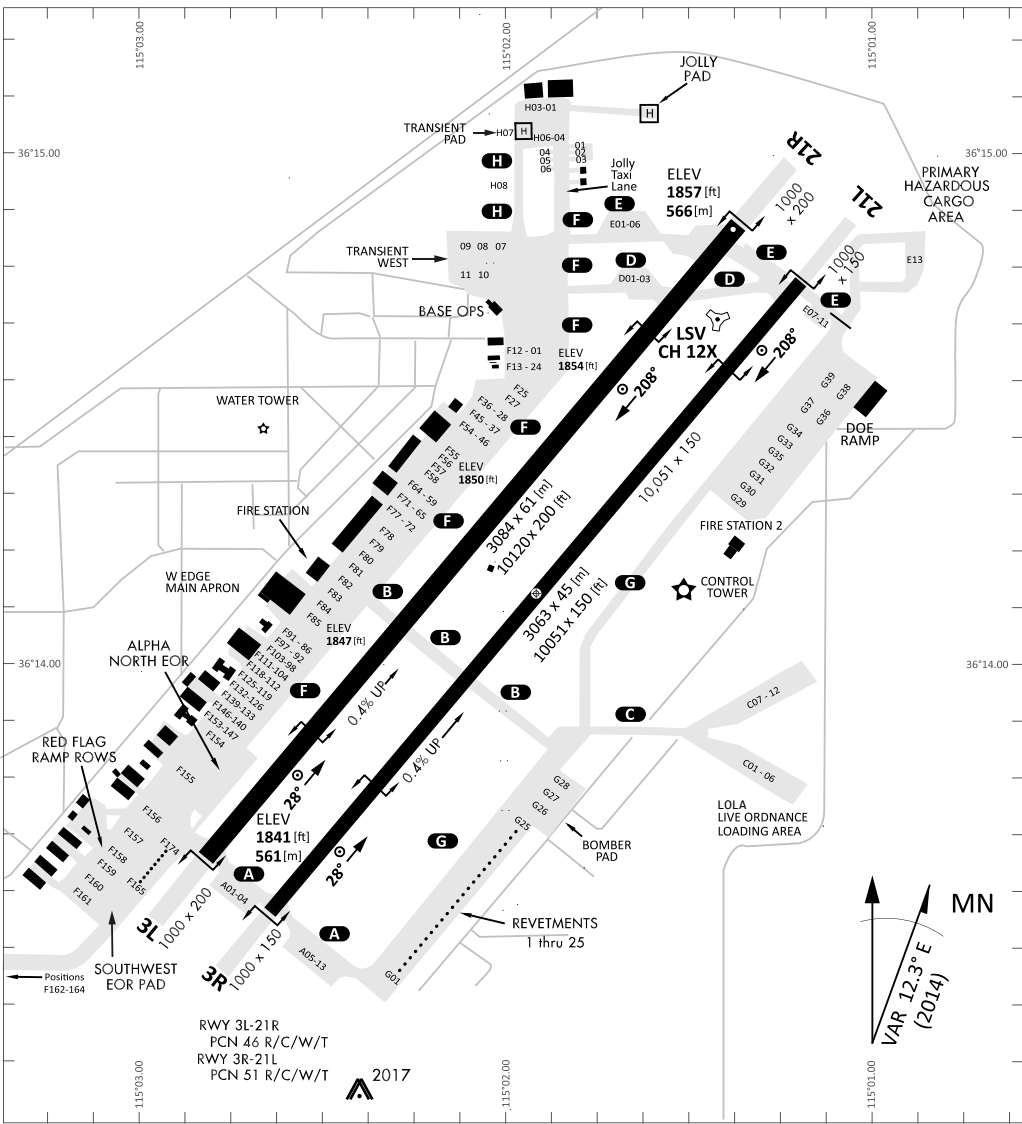

RWY 3L-21R
 PCN 46 R/C/W/T
 RWY 3R-21L
 PCN 51 R/C/W/T
 2017

PAR	RWY	CAT	MINIMA		ARP	ELEV	Scale 1:35'500	
	21L	A B D E	2057 - 0.8 200 (200-0.8/1.6)	GS 3°	36° 14.060° N 115° 01.058° W	1857 [ft] 566 [m]	0 300 600 900 1200 1500 [m]	
	3R	A B D E	2057 - 0.8 200 (200-0.8/1.6)	GS 3°			0 1000 2000 3000 4000 5000 [ft]	
SRA	21R	A C D E	2257 - 1.2 350 (350-1.2/1.6)					
	3L	A C D E	2257 - 1.2 350 (350-1.2/1.6)					

RWY	TORA	TODA	ASDA	LDA	PSN	THR	ALS
21L	10051 [ft] 3063 [m]	11051 [ft] 3368 [m]	11051 [ft] 3368 [m]	10051 [ft] 3063 [m]	36°14.043' N	115°01.018' W	⊕
3R	10120 [ft] 3084 [m]	11120 [ft] 3398 [m]	11120 [ft] 3398 [m]	10120 [ft] 3084 [m]	36°13.029' N	115°02.038' W	

ATIS	NELLIS GROUND	NELLIS TOWER	NELLIS CONTROL	TACAN	ILS RWY 21L	NELLIS EAST	NELLIS WEST
270.100 MHz	275.800 121.800	327.000 132.55	317.525	LSV 12X	109.10 Mhz	384.400	385.000

FYTTR LOW VISUAL OPERATION CHART | VALID 2014

ATIS
270.100
NELLIS GROUND
275.800
NELLIS TOWER
327.000
NELLIS CONTROL
317.525
NELLIS DEP/APP EAST
384.400
BLACKJACK
377.800

CAUTION: If unable to comply with restrictions advise ATC prior to departure.



VMC ONLY

PILOT RESPONSIBLE FOR TERRAIN AVOIDANCE

① 4 NM from RWY 3L/R

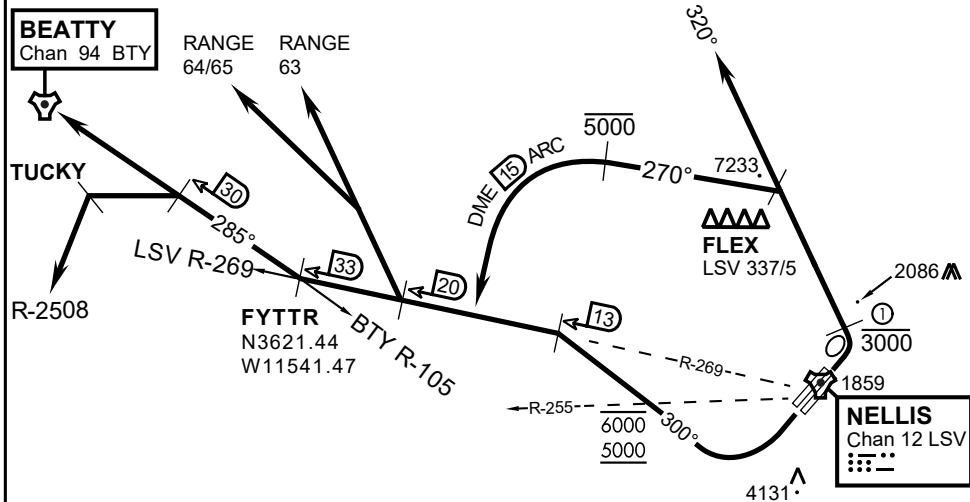

DEPARTURE ROUTE DESCRIPTION

TAKEOFF RWY 3L/R:

- Remain below 3,000' MSL until north of Race Track and turned westbound.
- Turn left within 4NM of Nellis direct FLEX. Fly north of FLEX and turn left heading 270°.
- Intercept LSV 15 DME ARC at or below 5,000' MSL.
- ARC south, intercept LSV R-269 outbound. Maintain VFR.

TAKEOFF RWY 21L/21R:

- Follow Noise Abatement Procedures.
- Fly runway heading until past Golf Course, turn right heading 300°.
- Cross LSV R-255 between 5,000' and 6,000' , intercept and proceed outbound on the LSV R-269.Recommend climb to 8,500' MSL or appropriate VFR altitude for overflight of North Las Vegas Training Area. Fly routing for appr. mission/transition.

TRANSITIONS:

- R-4806:** Turn right at the LSV 269/20 direct to assigned ranges.
- BEATTY:** Turn right at FYTTR direct BTY via the BTY R-105
- R-2508:** Turn right at the FYTTR, intercept the BTY 105/30, direct TUCKY, then direct R-2508

FYTTR DEPARTURE AND TRANSITIONS (FYTTR LOW)

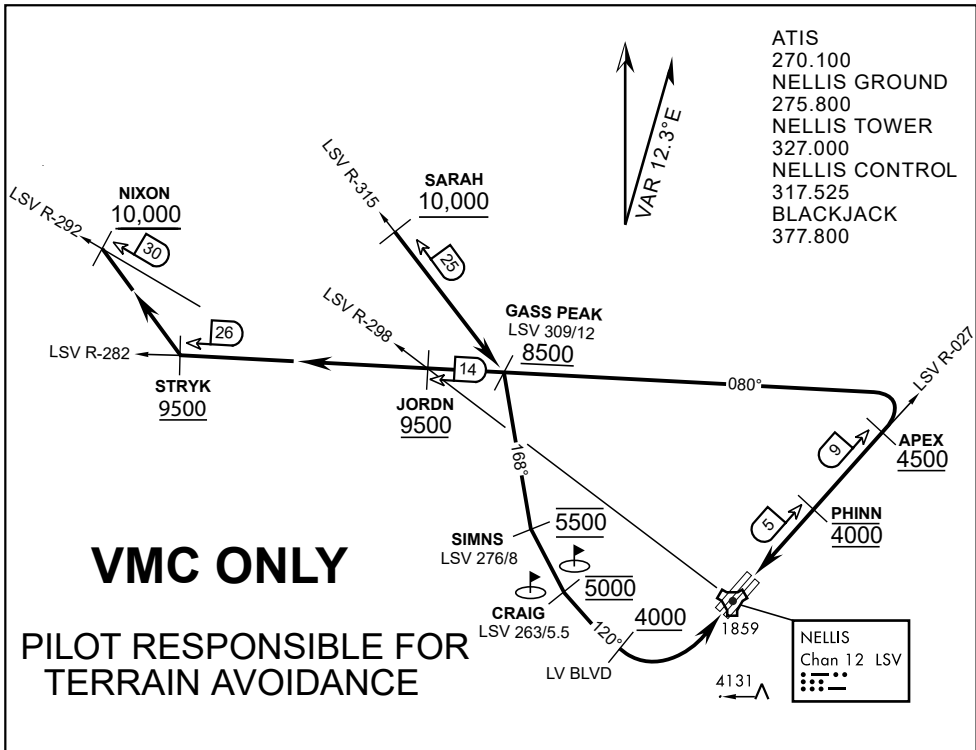

APPROACH ROUTE DESCRIPTION

APPROACH RWY 3L/R

Cross STRYK at or above 9,500' MSL, proceed direct GASS PEAK. Cross JORDN at or above 9,500' MSL, cross GASS PEAK at or above 8,500' MSL. Proceed direct SIMNS and cross at 5,500' MSL. Cross Las Vegas Blvd at or above 4,000' MSL then to 3,500' MSL for Initial. Remain within 4 DME if LSV on turn to final.

VFR STRAIGHT-IN RWY 3L/R

Depart CRAIG & descend to be at 3,000' MSL by Las Vegas Blvd. Do not descend below 3,000' MSL until within 5 DME of LSV or 4 NM of the runway on turn to final.

APPROACH RWY 21L/R

Cross STRYK at or above 9,500' MSL, proceed direct GASS PEAK. Cross JORDN at or above 9,500' MSL, cross GASS PEAK at or above 8,500' MSL. Cross APEX at or above 4,500' MSL then direct 5NM initial. Descend to cross PHINN at 4,000' MSL, Inside 5 NM descend to 3,500' MSL.

VFR STRAIGHT-IN RWY 21L/R

Cross APEX at 4,000' MSL. Descend to be at 3,000' MSL at PHINN. Descend to 3,000' MSL at LSV 027/5.

RANGE 63B EXIT

SOUTH: Via NIXON at or above 10,000' MSL, then direct STRYK.
EAST: Via SARAH at or above 10,000' MSL, then direct GASS PEAK.



INDIAN SPRINGS, NEVADA

TACAN INS Chan 87	APCH CRS 065°	Rwy ldg TDZE 3133	9002 3113
		Arpt Elev 3113	

INDIAN SPRINGS AF AUX (KINS)

▼ * MISSED APPROACH: Straight ahead to INS TACAN, intercept INS R-outbound, cross 17 DME at or above 9500, then direkt KSV TACAN 114

NELLIS CON

CREECH AFB TOWER
118.30 60.60

GND CON

NOT FOR CIVIL USE

FOR USE UNDER BASIC VFR
WEATHER MINIMUMS ONLY

PILOT IS RESPONSIBLE FOR TERRAIN/OBSTACLE AVOIDANCE AND APPROPRIATE VFR CLOUD CLEARANCE FOR ALL

CAUTION: Descent gradients are greater than allowed under standard TERPS criteria and inbound course does not meet straight-in criteria

CAUTION: Final approach course crosses Runway centerline at MIDFIELD. Maneuvering left of course required prior to landing. Do not Maneuver farther north than the INS R- 258

Modified by vJaBoG 66 for use with DCS
NOT FOR REAL LIFE NAVIGATION

Modified by vJaBoG 66 for use with DCS
NOT FOR REAL LIFE NAVIGATION

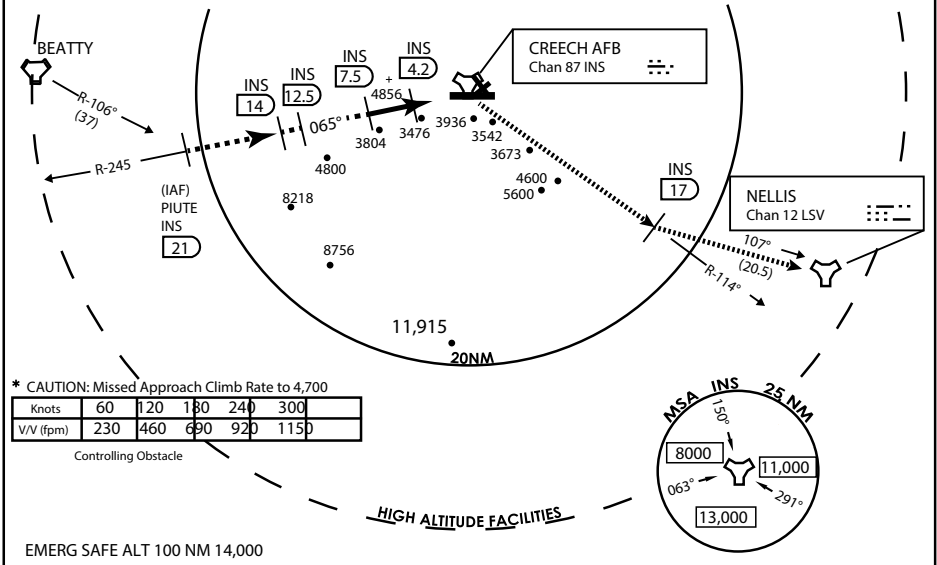

* CAUTION: Missed Approach Climb Rate to 4,700

Knots	60	120	180	240	300
V/V (fpm)	230	460	690	920	1150

Controlling Obstacle

HIGH ALTITUDE FACILITIES

EMERG SAFE ALT 100 NM 14,000

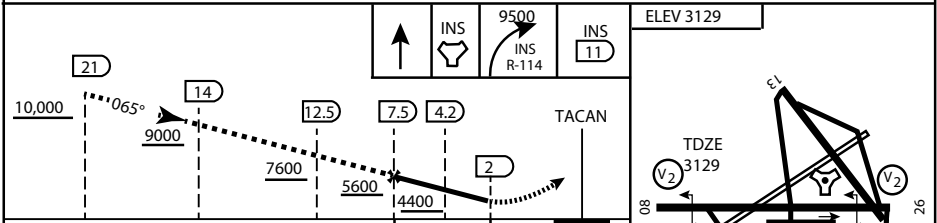

CATEGORY	A	B	C	D	E
S-8	3760-1 1/2	627 (700-1 1/2)	3760-1 3/4 627 (700-1 3/4)	3760-2 627 (700-2)	3760-2 1/4 627 (700-2 1/4)
CIRCLING	NOT AUTHORIZED				

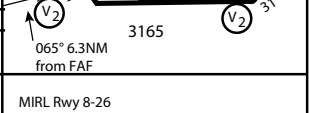

CITY OF INDIAN, NEVADA

INDIAN SPRINGS AF AUX (KINS)

(FOR DAY VFR USE ONLY)



