

MISSION DATA CARD

OPORD		Callsign		Mission		Date/Time		
3189/2024		Raptor 3		Training		092000SEP24		
Task	IFR Training Flight					Freq		
AO	blue route					134.0		
Departure				Recovery				
DREAM FOUR				HI-ILS or LOC/DME Z RWY 21L				
#	Callsign		Pilot		IFF	TCN	LSR	NET
-1	Raptor 3-1		Snowbird		1631	3Y	1621	

LOADOUT

A/A	2xA120C, 2xA9X				GUN	100% HEI-T	
A/G					CHF	120	
POD					FLR	0	
TKS	FT300				FUEL	100%	

TOLD

	Takeoff	Target	Joker	Bingo	Land
FUEL	9166			3000	

AIRBASES

	Name	TCN	ATIS	GND	TWR	RWY	Elev	ILS
Dep	Nellis AFB	12X	270.1	275.8	327.0	21L	1850	109.1
Arr	Nellis AFB	12X	270.1	275.8	327.0	21L	1850	109.1
Div	Creech AFB	87X	290.45	275.8	360.6			

COMMS

Radio	Usage
1	11,3,4,16,11,4,3

NOTES

Departure Dream 4 nach Dream

Fly Tacan: ILC (110) - Intercept Heading 012/71NM (Achtung für Tacan Inbound um 180° drehen)

Fly ILC (110) Outbound Heading 245/116NM to TQQ (77)

Fly TQQ (77) Outbound Heading 197/65NM to BTY (97)

Fly BTY (97) Outbound Heading 093/53NM to INS (87)

Recover via HI-ILS or LOC/DME Z RWY 21L

Cruise speed 350 IAS at 25.000, 2 Minutes Separation

SUPPORT**AWACS**

Callsign	Freq	ALT	Pos
MAGIC	377.8	FL270	N3749 W11417 - N3713 W11446

OTHER FLIGHTS

Callsign	Mission	Airframe	Freq	TCN	Grpld	Laser
Edelweiss 6	Training	2x A-10C	134.65	1/64	40	166X
AO	Nellis-Vegas-Nellis	Task	IFR-Route			
Raptor 1	Training	4x F-16C	134.0	1/64		162X
AO		Task				
Nazgul 6	Training	4x F-15E	262.45	21/84		156X
AO	R62 A20	Task	A/G Delivery			
Monster 1	Training	4x A-10C	132.15	1/64	21	161X
AO	R64C	Task	GUN TRAINING			
Rattler 1	Training	2x AH-64D	133.5	1/64		125X
AO	LATNC	Task				
Raptor 2	Training	4x F-16C	134.0	1/64		162X
AO	blue route	Task	IFR Training Flight			
Edelweiss 5	Training	1x F/A-18C	134.65	1/64	40	166X
AO	R64	Task	A2G Delivery			
Edelweiss 4	Training	1x F/A-18C	264.45	1/64		174X
AO		Task				
Tiger 1	Training	4x F/A-18C	261.15	1/64	1	155X
AO	Range 74.06 and 74.08	Task	AG Bomb, AAR and Formation			

RADIO CHANNELS

#	Freq	Name
1		Flight/Squadron specific
2	289.4	Nellis Clearance Delivery
3	275.8	Nellis Ground
4	327.0	Nellis Tower
5	385.4	Nellis Approach/Departure West
6	273.55	Nellis Approach/Departure East
7	317.525	Nellis Control -- Sally
8	254.4	Nellis Control-- Lee
9	305.6	SOF Bullseye
10	343.725	EMERGENCY SINGLE FRQ
11	270.1	Nellis ATIS
12	360.625	Creech AFB Tower
13	250.1	HAVE QUICK 13
14	251.1	HAVE QUICK 14
15	252.1	HAVE QUICK 15
16	377.8	Blackjack
17	265.0	KC-135 AR-641A
18	360.8	KC-135MPRS AR-635
19	319.8	KC-135MPRS AR-625
20	300.05	KC-135 AR-231V

RAMROD

0	1	2	3	4	5	6	7	8	9
C	R	E	M	A	T	I	O	N	S

KTC 1400 C

	0	1	2	3	4	5	6	7	8	9
A	YEBA	DQF	WGS	RJ	PH	TOI	XL	KU	CN	VM
B	LNXY	EPW	BQA	DG	IC	KOV	HF	RT	US	JM
C	GEXR	SHM	VCT	NQ	OP	UBW	ID	FA	LJ	KY
D	AQXO	BLN	EKD	IG	VM	HRF	UW	JT	PC	YS
E	QUXK	FPH	LMN	OI	ES	TRC	DW	AJ	GB	YV
F	XWCR	OJB	ANI	SG	YL	HQM	PK	UE	VF	DT
G	TMNC	JXH	FPG	DR	BK	EUO	AI	QY	WS	LV
H	MVOX	SQE	CUR	LY	NH	PGJ	WA	TB	DF	IK
I	QCJU	NYS	WGK	IP	RX	VOE	TL	HB	MF	AD
J	BVYR	HPM	EQW	FT	DI	NCJ	KG	LS	UA	XO
K	UDYH	AMK	QIX	OS	TG	CEJ	VN	FL	WR	PB
L	CNTQ	MHO	KPF	GR	JE	UYI	AD	VB	SL	XW
M	KAOU	SEF	QBR	LG	CN	TDI	WP	YJ	HV	XM
N	CIJE	NAD	TXO	FU	KQ	YPL	BS	VG	MR	WH
O	BXSP	RKO	NWF	VA	LQ	YEM	TU	HC	DJ	IG
P	TUNL	FBH	RIC	YK	GA	POQ	XW	ES	DV	JM
Q	BVUL	IWK	XNO	CR	SJ	FAE	YM	TP	GH	QD
R	JANU	BYX	QCP	KE	IF	WSR	LT	OD	MH	VG
S	WXCY	MVF	EBJ	SN	KR	HLU	PG	TO	DA	IQ
T	QYBH	LTF	MUV	JN	XR	ACK	SE	OW	PI	DG
U	QDCV	PLR	SXI	TM	YF	HWE	NG	JB	KU	OA
V	GYOV	LER	JTX	PI	SM	CDF	NA	UK	WQ	HB
W	RUYT	IQA	CVD	GH	NK	SFB	WM	LP	XO	JE
X	HCVK	DWS	YOB	QT	LX	UNF	PA	JM	GE	RI
Y	WNJK	PRO	ABH	QS	CM	IVE	FG	UT	YL	XD

NAVAIDS

Id	Name	Channel	Position	Elevation
BCE	Bryce Canyon	75	N3741.35 W11218.23	9040
BIH	Bishop	33	N3722.62 W11821.99	4114
BLD	Boulder	114	N3559.75 W11451.82	3650
BTY	Beatty	94	N3648.54 W11644.86	2925
CDC	Cedar City	120	N3747.24 W11304.90	5463
DAG	Daggett	79	N3457.75 W11634.69	1760
EED	Needles	99	N3445.96 W11428.43	650
GFS	Goffs	91	N3507.87 W11510.59	4019
GRL	Groom Lake	18	N3713.91 W11548.16	4475
HEC	Hector	74	N3447.83 W11627.78	1854
ILC	Wilson Creek	110	N3815.02 W11423.65	9318
INS	Creech AFB	87	N3635.20 W11540.12	3101
LAS	McCarran Intl	116	N3604.78 W11509.59	2142
LSV	Nellis	12	N3614.68 W11501.50	1864
MLF	Milford	58	N3821.62 W11300.79	4977
MMM	Mormon Mesa	90	N3646.16 W11416.65	2120
MVA	Mina	98	N3833.92 W11801.97	7860
OAL	Coale Dale	124	N3800.20 W11746.23	4800
PGS	Peach Springs	57	N3537.48 W11332.67	4754
TPH	Tonopah Muni	119	N3801.84 W11702.01	5330
TQQ	Silverbow	77	N3748.00 W11647.00	5500
UTI	St George	23	N3705.29 W11335.53	2871

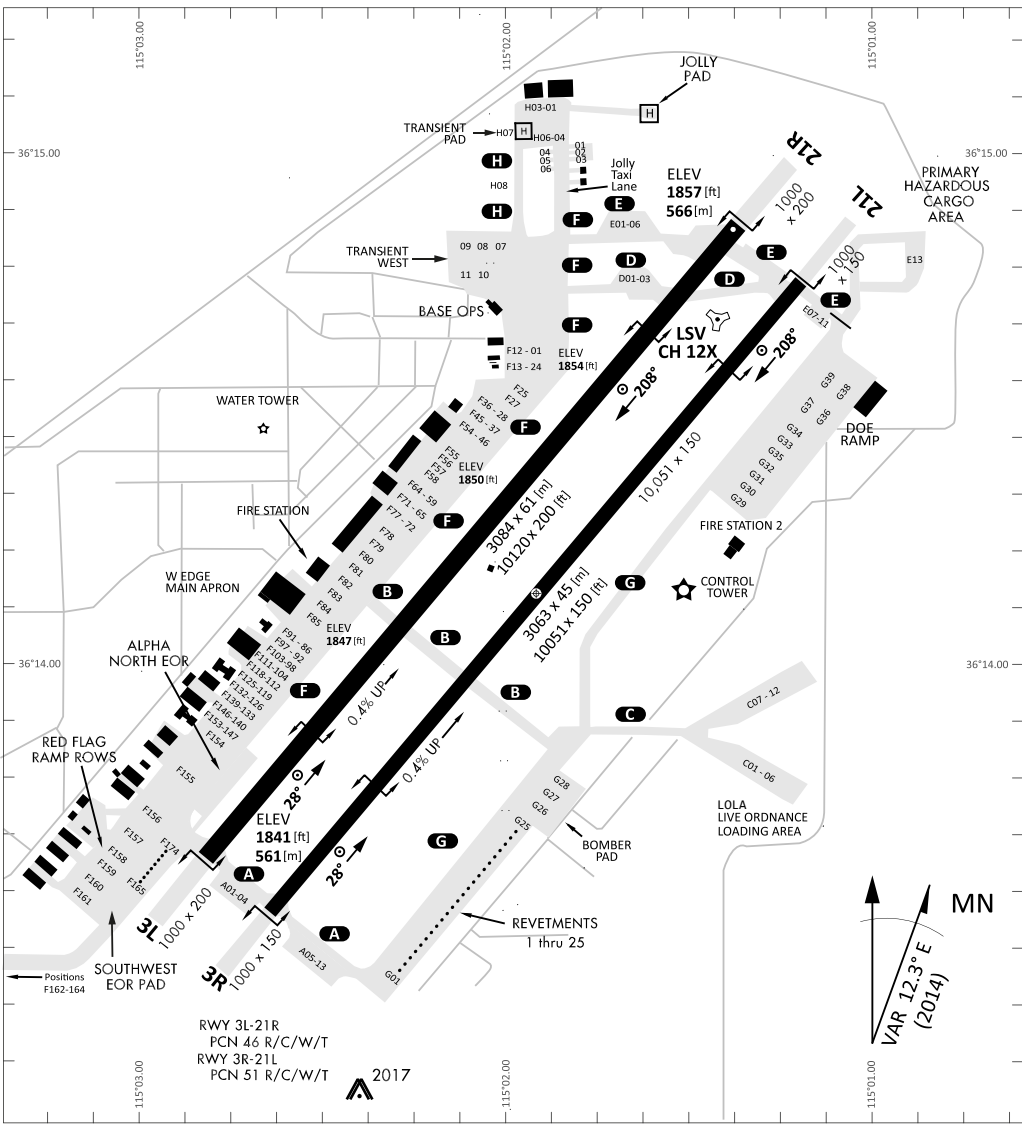

RWY 3L-21R
 PCN 46 R/C/W/T
 RWY 3R-21L
 PCN 51 R/C/W/T
 2017

PAR	RWY	CAT	MINIMA		ARP	ELEV	Scale 1:35'500	
	21L	A B D E	2057 - 0.8 200	(200-0.8/1.6) GS 3°	36° 14.060° N 115° 01.058° W	1857 [ft] 566 [m]	0 300 600 900 1200 1500 [m]	
	3R	A B D E	2057 - 0.8 200	(200-0.8/1.6) GS 3°			0 1000 2000 3000 4000 5000 [ft]	
SRA	21R	A C D E	2257 - 1.2 350	(350-1.2/1.6)				
	3L	A C D E	2257 - 1.2 350	(350-1.2/1.6)				

RWY	TORA	TODA	ASDA	LDA	PSN	THR	ALS
21L	10051 [ft] 3063 [m]	11051 [ft] 3368 [m]	11051 [ft] 3368 [m]	10051 [ft] 3063 [m]	36°14.043' N	115°01.018' W	⊕
3R	10120 [ft] 3084 [m]	11120 [ft] 3398 [m]	11120 [ft] 3398 [m]	10120 [ft] 3084 [m]	36°13.029' N	115°02.038' W	

ATIS	NELLIS GROUND	NELLIS TOWER	NELLIS CONTROL	TACAN	ILS RWY 21L	NELLIS EAST	NELLIS WEST
270.100 MHz	275.800 121.800	327.000 132.55	317.525	LSV 12X	109.10 Mhz	384.400	385.000

DREAM FOUR DEPARTURE DREAM4 | VALID 2014 NELLIS AFB (KLSV) LAS VEGAS, NEVADA

ATIS
270.100
NELLIS GROUND
275.800
NELLIS TOWER
327.000
NELLIS CONTROL
317.525
NELLIS DEP/APP EAST
384.400
BLACKJACK
377.800

DREAM
N3710.34
W11459.53

MINTT
LAS 351/38
17,000

Rwy	Knots	60	120	180	240	300	360
* 3 L (A)	V/V(fpm)	269	538	807	1076	1345	1614
* 3 R (B)	V/V(fpm)	245	490	735	980	1225	1470
† 3 L (C)	V/V(fpm)	498	996	1494	1992	2490	2988
† 3 R (C)	V/V(fpm)	496	992	1488	1984	2480	2976
* 21 L (D)	V/V(fpm)	389	778	1167	1556	1945	2334
* 21 R (D)	V/V(fpm)	395	790	1185	1580	1975	2370
† 21 L (C)	V/V(fpm)	453	906	1359	1812	2265	2718
† 21 R (C)	V/V(fpm)	457	914	1371	1828	2285	2742

* Minimum † ATC Climb Rate

- (A) to 3600
 - (B) to 3100
 - (C) to 17,000
 - (D) to 8500
- ** Lead DME:
ATALF - LSV 9.5
HEREM - LSV 8.8

- ① 12.24 NM from Rwy 21R
- ② 12.40 NM from Rwy 21L
- ③ 5.67 NM from Rwy 3L
- ④ 5.85 NM from Rwy 3R

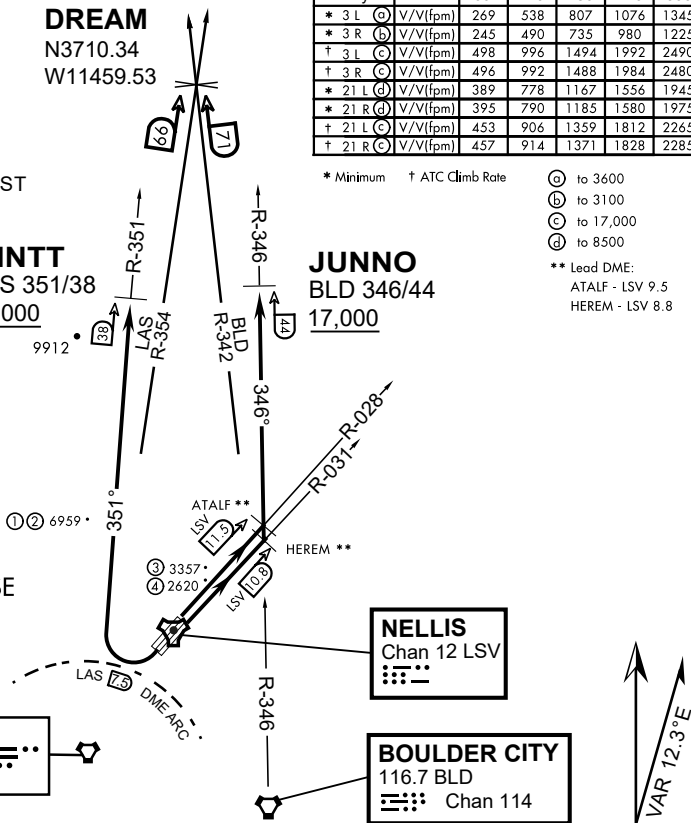

NOT FOR CIVIL USE

CAUTION: If unable to comply with restrictions advise ATC prior to departure.

DEPARTURE ROUTE DESCRIPTION

TAKE-OFF RWY 3L

- Fly runway heading to intercept the LSV TACAN R-028 then direct ATALF, intercept the BLD VORTAC R-346 then direct JUNNO, cross JUNNO at or above 17,000, then via assigned route.

TAKE-OFF RWY 3R

- Fly runway heading to intercept the LSV TACAN R-031 then direct HEREM, intercept the BLD VORTAC R-346 then direct JUNNO, cross JUNNO at or above 17,000, then via assigned route.

TAKE-OFF RWY 21L/R

- Turn right to intercept LAS VORTAC R-351 outbound. Remain North of LAS 7.5 DME turning Northbound. Intercept LAS R-351 between 5000 and 6000, do not proceed West of LAS R-351. Cross MINTT at or above 17,000, then via assigned route.

NOISE ABATMENT PROCEDURES: Fly acc. Nellis Noise Abatement instructions

DREAM FOUR DEPARTURE (DREAM4 • DREAM)

LAS VEGAS, NEVADA

HI-ILS or LOC Z RWY 21L

LOC I-DIQ 109.1	APCH CRS 209°	Rwy ldg	21L	21R
		TDZE	10,051	10,120
		Arpt Elev	1865	1869

JAL-227 (USAF)

NELLIS AFB (KLSV)

† When ALS inop, increase CAT CDE RVR to 40, vis to 3/4 mile.
 ** When ALS inop, increase CAT CDE vis to 1 3/4 miles.
 *** Circling not authorized E of Rwy 3R-21L.



† MISSED APPROACH: Climb to 15,000, intercept LSV TACAN R-210 to 2.5 DME (ROCKX), then climbing right turn heading 020° to join LSV R-358 to ARCOE and hold, continue climb-in-hold to 15,000. Missed approach not for civil use.

ATIS 270.1	APP CON 124.95 273.55	TOWER 132.55 327.0	GND CON 121.8 275.8	CLNC DEL 120.9 289.4
----------------------	---------------------------------	------------------------------	-------------------------------	--------------------------------

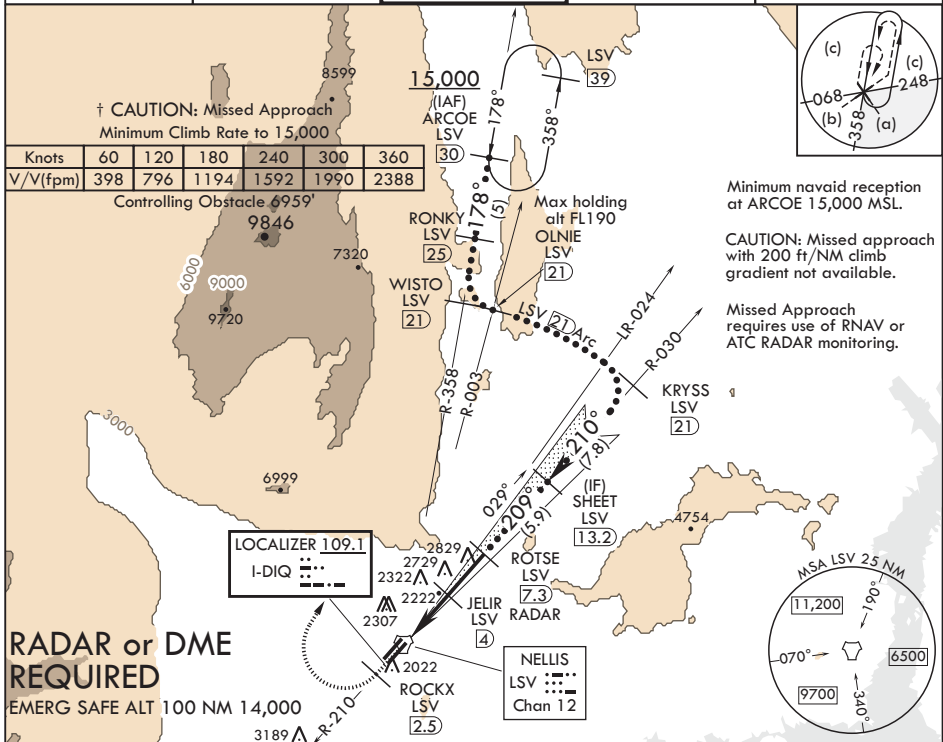

RADAR or DME REQUIRED

EMERG SAFE ALT 100 NM 14,000

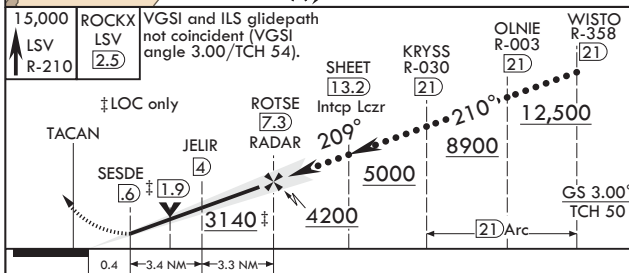

CATEGORY	C	D	E
S-ILS 21L*	2065-24	200	(200-1/2)
S-LOC 21L**	2480-1 3/8	615	(700-1 3/8)
SIDESTEP 21R	2500-1 3/4	631	(700-1 3/4)
⊕ CIRCLING***	2620-2 1/4 751 (800-2 1/4)	2840-3 971 (1000-3)	3040-3 1171 (1200-3)

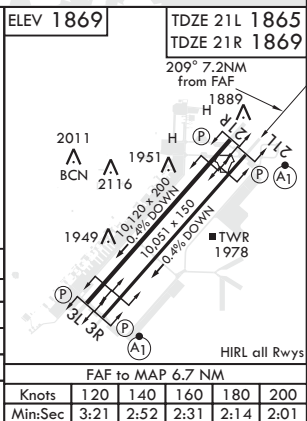

LAS VEGAS, NEVADA

36°14'N - 115°02'W

NELLIS AFB (KLSV)

Amdt 8 03JAN19

HI-ILS or LOC Z RWY 21L

SW-4, 05 DEC 2019 to 02 JAN 2020

SW-4, 05 DEC 2019 to 02 JAN 2020



INDIAN SPRINGS, NEVADA

TACAN INS Chan 87	APCH CRS 065°	Rwy ldg TDZE 3133	9002 3113
		Arpt Elev 3113	

INDIAN SPRINGS AF AUX (KINS)

▼ * MISSED APPROACH: Straight ahead to INS TACAN, intercept INS R-outbound, cross 17 DME at or above 9500, then direkt KSV TACAN 114

NELLIS CON

CREECH AFB TOWER
118.30 60.60

GND CON

NOT FOR CIVIL USE

FOR USE UNDER BASIC VFR
WEATHER MINIMUMS ONLY

PILOT IS RESPONSIBLE FOR TERRAIN/OBSTACLE AVOIDANCE AND APPROPRIATE VFR CLOUD CLEARANCE FOR ALL

CAUTION: Descent gradients are greater than allowed under standard TERPS criteria and inbound course does not meet straight-in criteria

CAUTION: Final approach course crosses Runway centerline at MIDFIELD. Maneuvering left of course required prior to landing. Do not Maneuver farther north than the INS R- 258

Modified by viaBog 66 for use with DCS
NOT FOR REAL LIFE NAVIGATION

Modified by viaBog 66 for use with DCS
NOT FOR REAL LIFE NAVIGATION

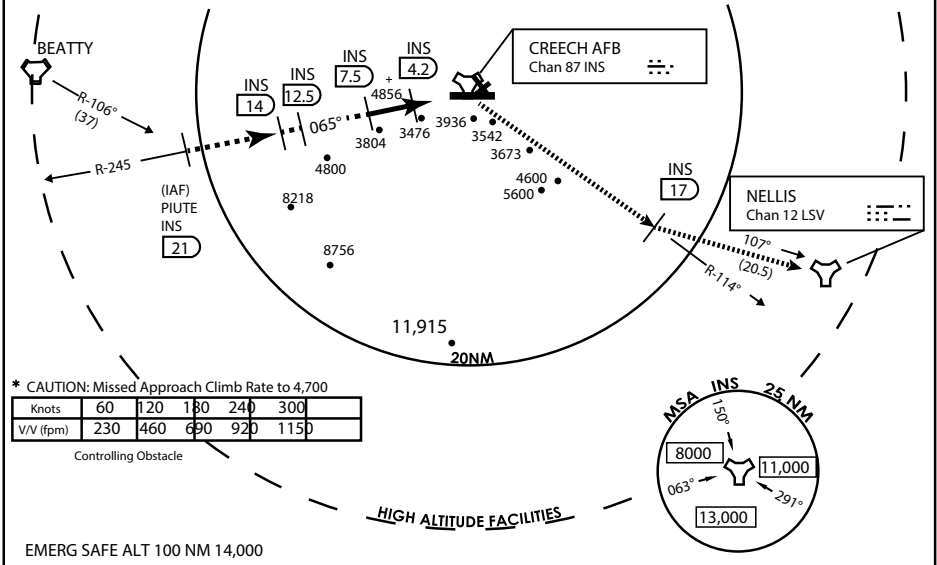

* CAUTION: Missed Approach Climb Rate to 4,700

Knots	60	120	180	240	300
V/V (fpm)	230	460	690	920	1150

Controlling Obstacle

HIGH ALTITUDE FACILITIES

EMERG SAFE ALT 100 NM 14,000

	INS 9500		INS 11	ELEV 3129																		
	INS R-114																					
<table border="1"> <tr> <th>CATEGORY</th> <th>A</th> <th>B</th> <th>C</th> <th>D</th> <th>E</th> </tr> <tr> <td>S-8</td> <td>3760-1 1/2</td> <td>627 (700-1 1/2)</td> <td>3760-1 3/4 627 (700-1 3/4)</td> <td>3760-2 627 (700-2)</td> <td>3760-2 1/4 627 (700-2 1/4)</td> </tr> <tr> <td>CIRCLING</td> <td colspan="5">NOT AUTHORIZED</td> </tr> </table>	CATEGORY	A	B	C	D	E	S-8	3760-1 1/2	627 (700-1 1/2)	3760-1 3/4 627 (700-1 3/4)	3760-2 627 (700-2)	3760-2 1/4 627 (700-2 1/4)	CIRCLING	NOT AUTHORIZED					MIRL Rwy 8-26			
CATEGORY	A	B	C	D	E																	
S-8	3760-1 1/2	627 (700-1 1/2)	3760-1 3/4 627 (700-1 3/4)	3760-2 627 (700-2)	3760-2 1/4 627 (700-2 1/4)																	
CIRCLING	NOT AUTHORIZED																					

CITY OF INDIAN, NEVADA

INDIAN SPRINGS AF AUX (KINS)

(FOR DAY VFR USE ONLY)



AIRPORT DIAGRAM

476 VFG

CREECH AFB (KINS)
INDIAN SPRINGS, NEVADA

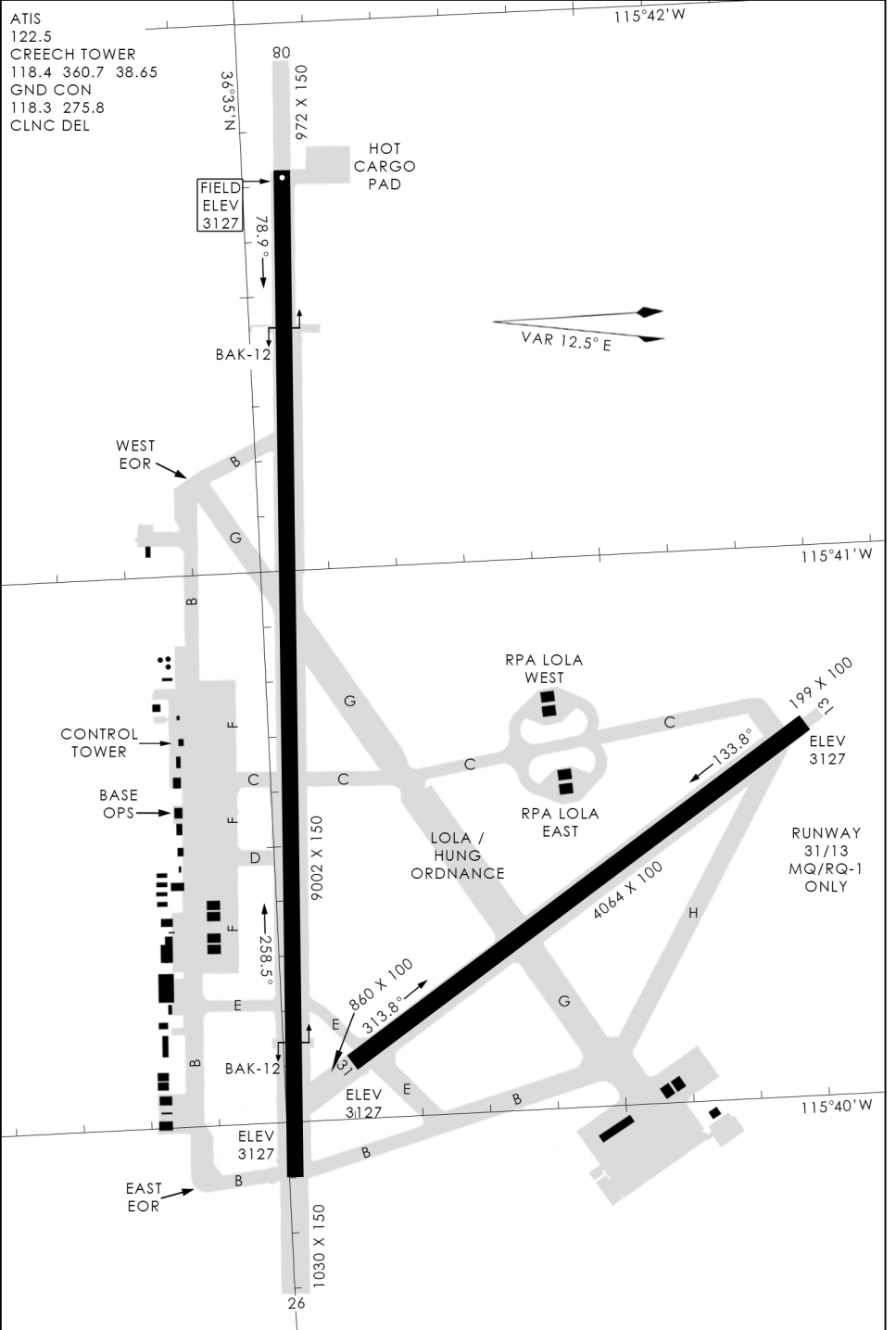

476 VFG JAN 2019

476 VFG JAN 2019

AIRPORT DIAGRAM

INDIAN SPRINGS, NEVADA
CREECH AFB (KINS)